

Improving Power Efficiency in Cooperative Diversity and MIMO Systems by Using Star QAM

Abdussayeed Khan, Mohammad Shabber Hasan Khan

Master of Science in Electronics

Master of Science in Electronics

Abstract

In this paper, we propose a new simple relaying strategy based on bit-interleaved convolutionally coded starquadrature amplitude modulation (QAM) along with coherent/ noncoherent detection. Exploiting this property, a hard limiter is used to enhance power amplifier (PA) efficiency at the relay. Here we are using the higher order modulation for improving relay communication, and also employ the accurate relay technique. Moreover, we show that the proposed approach retains differential detectability, which results in a significant reduction of receiver complexity with robustness against phase ambiguity, by analyzing our proposed method in terms of asymptotic pairwise error probability (PEP), Furthermore, the effectiveness of the proposed scheme in terms of PA efficiency is confirmed by comparing the statistical distributions of the corresponding instantaneous signal power. And also implement the PEP in MIMO systems for improving the powerefficiency. All the theoretical results agree with those obtained by computer simulations.

Index Terms—Cooperative diversity, power amplifier (PA)efficiency, star-quadrature amplitude modulation (star-QAM), differential amplitude-and-phase shift keying (DAPSK), amplify and- forward (AF),MIMO systems.

I. Introduction

Utilization of terminals distributed in space can significantly improve the performance of wireless networks

[1]–[3]. For example, pair of neighboring nodes with channel state information (CSI) can cooperatively *beamform* towards the final destination to increase total capacity [2]. Even when CSI is not available or when radio hardware cannot support beamforming, cooperation between the source and a single relay provides improved robustness to wireless fading [3]. Basic results for cooperation are presented in [4]–[6] and references therein. Scaling cooperation to more than one relay is still an open area of research, despite the recent interest in cooperative communication. One possible approach is the use of distributed space–time coding among participating nodes [7]. In practice, such code design is quite difficult due to the *distributed* and *ad-hoc* nature of cooperative links, as opposed to codes designed for co-located multiple-input multiple output (MIMO) systems [8]–[10]. The need and availability of global CSI is fundamental in distributed environments. For example, additional communication is needed for each relay to acquire CSI about other relays (as needed in [11]) or for the destination to acquire CSI between the source and *all* relays (as needed in [12]). Moreover, the number of *useful* antennas (distributed relays) for cooperation is generally unknown and varying. Therefore, coordination among the cooperating nodes is needed prior to the use of a

specific space–time coding scheme, typically designed for a fixed number of transmit antennas. Furthermore, it is often assumed in the literature that the superposition of signals transmitted by several relays is *always constructive*.¹ such assumption requires distributed phased-array techniques (beamforming) and unconventional radios, thereby increasing complexity and cost of each transmitter. Finally, *coherent* reception of multiple-relay (MR) transmissions requires tracking of carrier-phase differences among *several* transmit receivepairs, which increases the cost of the receiver. Therefore, simplification of radio hardware in cooperative diversity setups is important. Antenna selection, invented for classical multiple-antenna communications [14]–[18], is one approach to minimize the required *cooperationoverhead* and to simultaneously realize the potential benefits of cooperation between multiple relays. In particular, a simple, distributed, single-relay selection algorithm was proposed for slow fading of the wirelessrelay channels [19]. This single-relay *opportunistic* selection provides no performance loss from the perspective of diversity–multiplexing gain tradeoff, compared to schemes that rely on distributed space–time coding. In this paper, we present single-selection—*opportunistic*— relaying with decode-and-forward (DaF) and amplify-and forward (AaF) strategies and analyze their outage probability under an aggregate power constraint.² The motivation behind imposing the aggregate power

constraint is threefold: (i) transmission power is a network resource that affects both the lifetime of the network with battery-operated terminals and the scalability of the network; (ii) regulatory agencies may limit total transmission power due to the fact that each transmission can cause *interference* to the others in the network; and (iii) cooperative diversity benefits can be exploited even when relays *do not* transmit (and therefore, do not add transmission energy into the network). We consider both *reactive* and *proactive* relay selection depending on whether the relay selection is performed after or before the source transmission. This paper is organized as follows. In Section II, we briefly describe a system model and the three relay functions; AF, DetF, and our proposed relaying with either coherent or differential detection. Section III analyzes an asymptotic pairwise error probability (PEP) of the proposed system and shows that it can achieve the full diversity order on the condition that the minimum free distance of the convolutional codes is larger than the predetermined value specified by the number of relay terminals regardless of detection schemes. In Section IV, an asymptotic peak power efficiency is theoretically analyzed under the band-limited scenario. In Section V, theoretical results and the effectiveness of PA efficiency are confirmed by computer simulations. Finally, Section VI concludes this work.

In this paper, we propose a new *simple* relaying strategy based on bit-interleaved convolutionally coded star-QAM. Star-QAM was originally proposed as a special case of circular amplitude and phase shift keying (APSK) modulation [11] which is advantageous to square-shaped QAM modulation in terms of achievable mutual information over peak power limited channels [12, 13] and has recently become widely adopted, due primarily to its inclusion in the second generation of the Digital Video Broadcasting Satellite standard, DVBS2[14, 15], as

well as some other satellite standards such as DVB-SH, IPoS, and ABS-S. Star-QAM is composed of multiple concentric circles of phase-shift keying (PSK), where every PSK ring has the same number of symbols and is constructed with an identical phase offset. The main advantage of star-QAM constellation is mutual independence between amplitude and phase of each signal point in the constellation [16, 17]. This unique property allows the receiver to use differential detection instead of coherent detection, which requires neither a channel estimation nor accurate phase tracking at the receiver. Star-QAM, hence, was principally investigated with differential detection [18–21] and is also referred to as a *differential amplitude and phase shift keying* (DAPSK) in the literature [22]. In this paper we exploit this unique property of star-QAM signaling; independence of phase and amplitude. The relay suppresses the amplitude variation of the received signals due to the use of a hard limiter [23] and transmits the resulting PSK signals in order to enhance the PA efficiency at the relay. It is worth noting that, in our proposed approach, its complexity is comparable to AF relaying rather than DetF relaying since neither demodulation nor decoding is required during relaying process. Moreover, owing to the property of star-QAM constellation, our approach has *differential detectability*, which does not require accurate channel estimation. A study on single and multiple relay systems using differential phase shift keying (DPSK) modulation can be found in [24] and [25], respectively. These conventional approaches with differential detection lead to a low complexity receiver structure but apparently face with a considerable reduction of PA efficiency as the bandwidth efficiency increases. On the other hand, our approach with differential detection can achieve higher bandwidth efficiency with neither increase of complexity nor reduction of PA efficiency.

II. PROPOSED METHOD

2.1. Cooperative Relaying Model:

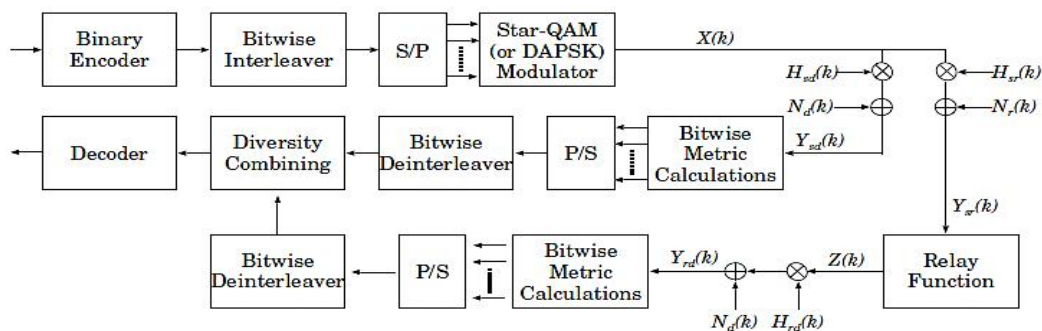

Fig. 1. The system model of bit-interleaved coded star-QAM using one relay, where P/S and S/P denote parallel-to-serial and serial-to-parallel operations, respectively.

In this paper, we consider a network consisting of the three terminals denoted as source, relay, and destination. Each terminal is equipped with a single antenna and the relay is subject to the half-duplex constraint. That is, we assume that while listening to the channel, the relay may not transmit. Figure 1 shows the mathematical system model with this single relay scenario. Throughout the paper, we consider a star-QAM constellation. Star-QAM is composed of $2(m-n)$ concentric circles of $2n$ -ary PSK. A radius of the l th circle is given by

$$A_l = \alpha^l \sqrt{\frac{2^{m-n}}{\sum_{l=0}^{2(m-n)-1} \alpha^{2l}}}, \quad (1)$$

When a differential detection is assumed at the receiver side, the corresponding differential encoding at the source is necessary. Let the k th transmit symbol be denoted as $X(k) = rke^{j\theta k}$, where r and θ denote the envelope and the angle of the k th transmit signal, respectively. Then, the first n bits of the k th codeword choose the phase difference between two consecutive symbols θ_k and θ_{k-1} together with Gray labeling while the remaining $(m-n)$ bits choose the amplitude difference between r_{k-1} and r_k [20]. For 16-DPSK systems, the first three coded bits choose the phase difference between two consecutive symbols and remaining one coded bit, say $c \in \{0, 1\}$, chooses $r_k \in \{A_0, A_1\}$ by the following rule:

2.2. Conventional Relaying:

2.2.1. AF Relay: When the envelope of the channel coefficient of the source-relay link is fully available at the relay, AF relay can be used [5]. The relay function of AF relaying is then given by

$$r_k = \begin{cases} r_{k-1}, & \text{for } c = 0 \\ \bar{r}_{k-1}, & \text{for } c = 1, \end{cases} \quad (2)$$

In the case of AF relaying, neither demodulation nor decoding is needed at the relay since the relay only retransmits the amplified version of the received signal

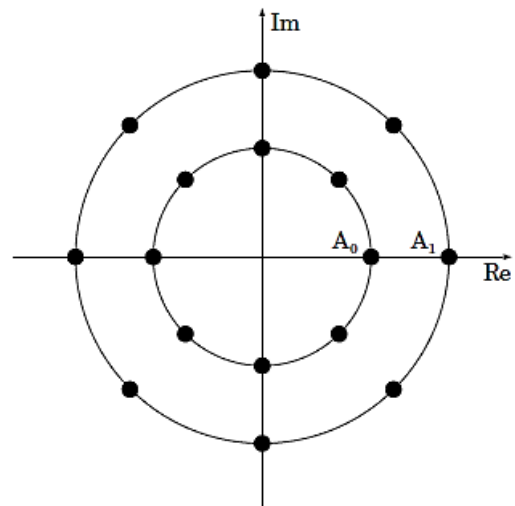

Fig. 2. The complex signal constellation of 16-ary star-QAM.

$$f(Y(k)) = G_{AF} \times Y_{sr}(k), \quad G_{AF} \triangleq \sqrt{\frac{1}{H_{sr}^2 + \sigma^2}}. \quad (3)$$

2.2.2. Coherent Detect-and-Forward (CDetF) Relay:

In the case of CDetF relaying, the relay detects the received signal and transmits a regenerated signal. Hence, the relay function of this relaying with coherent detection can be given by

$$f(Y_{sr}(k)) = \underset{Z(k) \in \mathcal{X}}{\operatorname{argmin}} |Y_{sr}(k) - H_{sr}(k)Z(k)|^2. \quad (4)$$

2.2.3. Noncoherent Detect-and-Forward (NDetF) Relay:

Similarly as in the CDetF relaying, a NDetF relay retrieves the original signals by using the differential detection without decoding. According to [20], the estimated phase difference $\Delta \hat{\theta}_k$ is given by

$$\Delta \hat{\theta}_k = \underset{\Delta \theta_k}{\operatorname{argmin}} \left[-\frac{|Y(k)||Y(k-1)|\gamma_k \cos(\Delta \phi_k - \Delta \theta_k)}{1 + \gamma_k^2} \right]. \quad (5)$$

2.2.4. The Proposed Relaying:

To avoid an event that high instantaneous power of the transmitted signal at the relay occurs, we propose a new simple relaying technique using a hard limiter [23] whose complexity is less than that of AF relaying since it does not require any knowledge of wireless links. Figure 3 illustrates the relationship between the input and output envelope levels of the hard limiter in comparison with that of AF relaying where G_{AF} is assumed to be one. As observed from the figure, hard limiter always provides a given constant amplitude for any input envelope. The proposed relaying utilizes this unique characteristic of hard limiter to suppress the amplitude variation of received signal while retaining its phase rotation and then transmits the signals with the constant envelope, which can be mathematically expressed as

$$f(Y(k)) = e^{j\phi k}, \quad (6)$$

Where ϕk denotes the angle of the k th received signal. After the hard limitation, the constellation of $2m$ -ary star-QAM reduces to that of $2n$ -ary PSK because of the elimination of amplitude information as depicted in Fig. 4. Hereinafter, let M denote a set of complex PSK signal points with $|M| = 2n$ and unit average energy.

III. PERFORMANCE ANALYSIS AND DESIGN CRITERIA OF THE PROPOSED RELAYING

In this section, we analyze an asymptotic PEP of the proposed approach along with coherent and noncoherent detections to show that our proposed approach can achieve full diversity (i.e., diversity order of two in this scenario). Based on these analytical results, essential design criteria of the proposed relaying are presented.

3.1. Coherent Detection:

A code rate R convolutional encoder with minimum free distance d is assumed to generate the binary code sequence \mathbf{c} at the source. If the bitwise interleaved is ideal, the PEP of two code words \mathbf{c} and $\tilde{\mathbf{c}}$ conditioned on H_{sr}, H_{rd}, H_{sd} can be expressed as

$$\Pr(\mathbf{c} \rightarrow \tilde{\mathbf{c}} | H_{sr}, H_{rd}, H_{sd}) \leq \Pr \left[\sum_{t, d_{\text{free}}} \lambda_{c_t}^i(k) \geq \sum_{t, d_{\text{free}}} \lambda_{\tilde{c}_t}^i(k) \right]$$

3.2. Noncoherent Detection:

Similar to the coherent case, the proposed approach can be regarded as the bit-interleaved coded DPSK and thus the theoretical approach in [33] can be applied. Thus, from suboptimal Gaussian metric instead of bit metrics described in Section II-D2, the PEP without any channel information can be written as

$$\Pr(\mathbf{c} \rightarrow \tilde{\mathbf{c}}) \leq \Pr(\mathbf{c}' \rightarrow \tilde{\mathbf{c}}') \leq E_{H_{sd}, H_{sr}} \left[\left(\frac{1}{1 - (2\lambda)^2 d_{\text{min}}^2} \right)^{d'_{\text{free}}} \times \exp \left[- \frac{2\lambda(1 - 4\lambda)d_{\text{min}}^2}{1 - (2\lambda)^2 d_{\text{min}}^2} \left(\frac{E_s}{N_0} A_0^2 |H_{sd}|^2 + \frac{E_r}{N_0} |H_{rd}|^2 \right) \right] \right]$$

3.3. Complementary Cumulative Distribution Function (CCDF) of Instantaneous Power:

Let $s(\tau; H)$ indicate a complex baseband signal at the relay using the arbitrary fading realization H which is a positive real random variable following Rayleigh distribution with unit variance. Then $s(\tau; H)$ is denoted by [9] where τ is a continuous time scale normalized by its symbol period, $g(\tau)$ is the impulse response of the pulse shaping filter with unit average energy, K is an effective length of $g(\tau)$ of one-sided impulse response, and $ak(\tau), g(k + \tau)$. For

given time instant $\tau \in [0, 1)$ and fading coefficient H , the probability that the instantaneous power

$$s(\tau; H) \triangleq \sum_{k=-K}^K Z(k)g(k + \tau) = \sum_{k=-K}^K a_k(\tau)Z(k), \quad \text{for } 0 \leq \tau < 1$$

3.4. MIMO systems:

MIMO antenna configuration. In spatial multiplexing, a high rate signal is split into multiple lower rate streams and each stream is transmitted from a different transmit antenna in the same frequency channel. If these signals arrive at the receiver antenna array with sufficiently different spatial signatures and the receiver has accurate CSI, it can separate these streams into (almost) parallel channels.

IV. NUMERICAL RESULTS

In this section, we evaluate the performance of our proposed approach via computer simulations. We first define a relative IBO gain to evaluate PA efficiency and show performance in terms of the CCDFs. Then, we show the performance comparison in terms of bit error rate (BER) without considering the effect of PA. Afterwards, we investigate the performance of the three different cooperative approaches in the presence of IBO of PA.

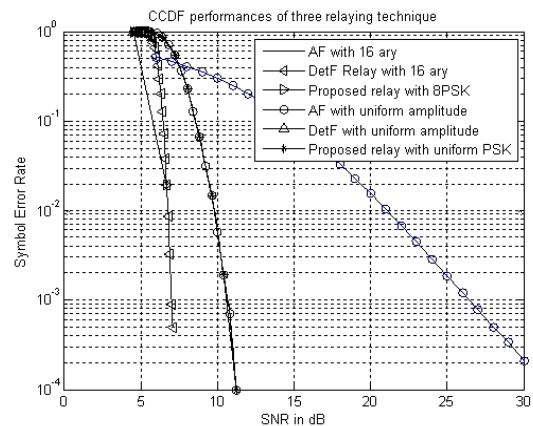

4.1. Instantaneous Power Distributions of Different Relay Functions:

We here show some numerical examples for instantaneous power distributions to evaluate PA efficiency. Figure 6 shows the theoretical curves for the average CCDF of AF (uniform amplitude disk), DetF (uniform amplitude disk), and the proposed relaying (uniform PSK), where the SNR between the source and relay is assumed to be 10 dB or 20 dB. As seen in the figure, AF relaying has higher instantaneous power than that of the other relays due to the noisy characteristic of transmit signals before the pulse shaping filter. Thus, the higher the SNR

between the source and relay, the more rapidly the CCDF curve of the AF relay drops owing to the diminution of noisy components

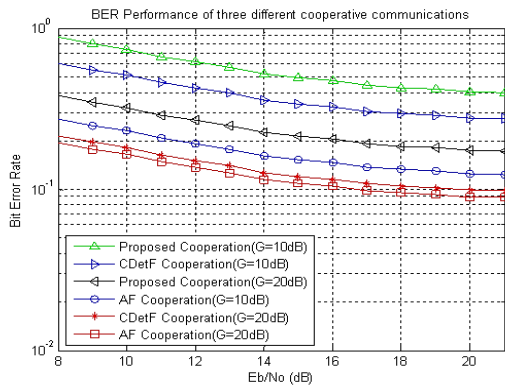

of the proposed approach. In the following, the root raised-cosine (RRC) pulse with a roll-off factor ν is assumed as $g(\tau)$, where its closed form expression is given by [9]

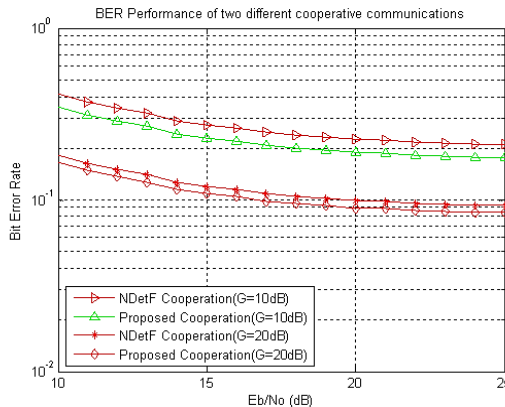

$$g(\tau) = \frac{\sin(\pi(1-\nu)\tau) + 4\nu\tau \cos(\pi(1+\nu)\tau)}{\pi\tau\{1 - (4\nu\tau)^2\}}$$

While the DetF relay exhibits lower CCDF performance than those of AF relay, there is still a gap between the proposed and DetF relaying, which is about 3.3 dB at CCDF = 10⁻³. Note that this gap essentially leads to the improvement in the PA efficiency.

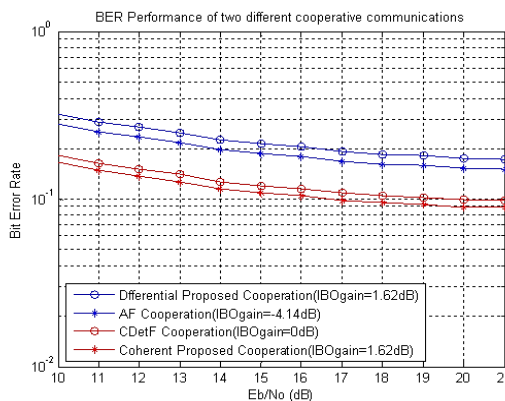

4.2. BER Performance without IBO Effects:

1) *Performance of Coherent Detection:* We start with the BER comparison without considering IBO effects, where every receiver can use the coherent detection to retrieve transmitted information. The convolutional code with half rate (133, 171)8 and $d_{free}=10$ is assumed and a multiple random interleaver is used, which meets all the design criteria provided in Section III. The information size is 2048 bits and the ring ratio α of star-QAM is assumed to be 2.0 as a typical value. To consider the geometrical proximity, we assume that the average received signal power at the relay is assumed to be $G = 10$ dB or 20 dB higher than that at the destination. Figure 7 shows the BER performance of the aforementioned three cooperative transmissions; AF, CDetF, and proposed

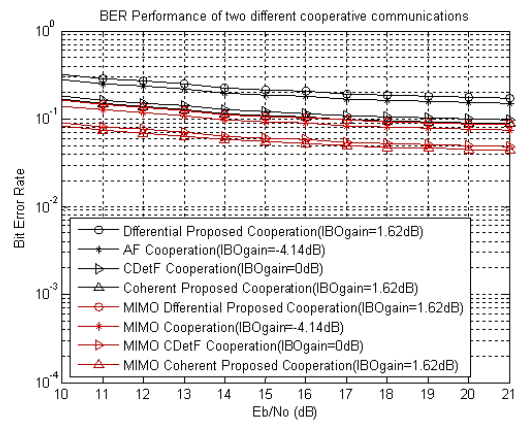

Performance Comparison with IBO Effects

Finally, we show the BER performances in the presence of IBO effects. From the results in Section V-B, Fig. 9 shows the BER performance of AF, CDetF, and the proposed relays using coherent or noncoherent detection in the presence of relative IBO gain at the relay. Interestingly, the performance of the proposed approach based on coherent detection is always superior to that of the other relays owing to PA leading to effective reduction of instantaneous high power signals. With the coherent detection scenario, the performance gain of our proposed approach is about 2.4 dB and 0.4 dB compared with AF and CDetF cooperation at BER = 10⁻³, respectively. Moreover, the proposed cooperation with differential detection approaches AF relay with coherent detection despite its simple structure while there is 1 dB energy loss in the presence of relative IBO gain. Therefore, our proposed approach is much beneficial in terms of BER performance in addition to PA efficiency and circuit simplicity.

V. CONCLUSIONS

In this paper, the power efficient relaying strategy together with bit-interleaved convolutionally coded star-QAM has been proposed in combination

with coherent and differential detection. Based on the asymptotic PEP analysis, the design criteria of our proposed approach were investigated and our results indicated that full diversity for the proposed approach is guaranteed regardless of the detection techniques. We also derived the CCDFs of AF and DetF relays with uniform amplitude disk, which confirmed the effectiveness of PA efficiency of the proposed approach. The benefits of the proposed approach under the consideration of PA efficiency were confirmed by the numerical results. Moreover, although AF relaying can be seen as an attractive candidate for low complexity relaying compared with DetF relaying, the proposed approach requires neither channel state information nor detection at the relay. Our proposed approach, hence, can be considered as a practical cooperative diversity relaying suitable for energy limited applications. We can also implement the proposed relaying technique in MIMO system.

ACKNOWLEDGMENTS

The authors would like to thank the Associate Editor and anonymous reviewers for their comments that improved the quality of manuscript.

REFERENCES

- [1] T. M. Cover and J. A. Thomas, *Elements of Information Theory*. John Wiley & Sons, Inc., 1991.
- [2] A. Sendonaris, E. Erkip, and B. Aazhang, "User cooperation diversity— part I: system description," *IEEE Trans. Commun.*, vol. 51, no. 11, pp. 1927–1938, Nov. 2003.
- [3] M. Dohler, A. Gkelias, and A. Aghvami, "Capacity of distributed PHY layers sensor networks," *IEEE Trans. Veh. Technol.*, vol. 55, no. 2, pp. 622–638, Mar. 2006.
- [4] A. Bletas, H. Shin, and M. Win, "Cooperative communications with outage-optimal opportunistic relaying," *IEEE Trans. Wireless Commun.*, vol. 6, no. 9, pp. 3450–3460, Sept. 2007.
- [5] J. N. Laneman, D. N. C. Tse, and G. W. Wornell, "Cooperative diversity in wireless networks: efficient protocols and outage behavior," *IEEE Trans. Inf. Theory*, vol. 50, no. 12, pp. 3062–3080, Dec. 2004.
- [6] T. Islam, R. Schober, R. Mallik, and V. Bhargava, "Amplify-and-forward cooperative diversity for BICM-OFDM systems," in *Proc. 2010 IEEE GLOBECOM*.
- [7] K. Ishibashi and H. Ochiai, "Analysis of instantaneous power distributions for non-regenerative and regenerative relaying signals," *IEEE Trans. Wireless Commun.*, vol. 11, no. 1, pp. 258–265, Jan. 2012.
- [8] M. Benjillali and L. Szczecinski, "Detect-and-forward in two-hop relay channels: a metrics-based approach," *IEEE Trans. Commun.*, vol. 58, no. 6, pp. 1729–1736, June 2010.
- [9] H. Ochiai, "Exact and approximate distribution of instantaneous power for pulse-shaped single-carrier signals," *IEEE Trans. Wireless Commun.*, vol. 10, no. 2, pp. 682–692, Feb. 2011.
- [10] M. Tanahashi and H. Ochiai, "Trellis shaping for controlling envelope of single-carrier high-order QAM signals," *IEEE J. Sel. Topics Signal Process.*, vol. 3, no. 3, pp. 430–437, May 2009.
- [11] C. Thomas, M. Weidner, and S. Durrani, "Digital amplitude-phase keying with m -ary alphabets," *IEEE Trans. Commun.*, vol. COM-22, no. 2, pp. 168–180, Feb. 1974.
- [12] S. Shamai (Shitz) and I. B. David, "The capacity of average and peak power-limited quadrature gaussian channels," *IEEE Trans. Inf.*, vol. 41, no. 4, pp. 1060–1071, July 1995.
- [13] R. M. Müller, U. Wachsmann, and J. Huber, "Multilevel coding for peak power limited complex Gaussian channels," in *Proc. 1997 Int. Symp. Inf. Theory*, p. 103.
- [14] R. Gaudenzi, A. I. F. Abregas, and A. Martinez, "Turbo-coded APSK modulations design for satellite broadband communications," *International J. Satellite Commun. Netw.*, vol. 24, pp. 261–281, July 2006.
- [15] "Performance analysis of turbo-coded APSK modulations over nonlinear satellite channels," *IEEE Trans. Wireless Commun.*, vol. 5, no. 9, pp. 2396–2407, Sept. 2006.
- [16] W. T. Webb, L. Hanzo, and R. Steele, "Bandwidth efficient QAM schemes for Rayleigh fading channels," *IEE Proc.-I*, vol. 138, no. 3, pp. 169–175, June 1991.
- [17] D. Makrakis and P. T. Mathiopoulos, "Trellis coded non-coherent QAM: a new bandwidth and power efficient scheme," in *Proc. 1989 IEEE VTC— Spring*, pp. 95–100